



# AQUATru<sup>®</sup>

connect 

## AT2030

Owner's Manual



This AT2000, AT2010, AT2020, AT2030, AT2040 and AT2050 system has been certified by IAPMO against NSF/ANSI standard 42, 53, 58, 401 and P473 for the reduction claims specified on the performance data sheet as verified and substantiated by test data and at [IAPMO.org](http://IAPMO.org)

# Thank You

---



Thank you for purchasing the AquaTru® Ultra Reverse Osmosis® Countertop water purifier! This state-of-the-art water purification system will greatly improve the quality and taste of your water. AquaTru is a healthy choice and a great way to save money while being environmentally friendly. We want you to be fully satisfied with your AquaTru water purifier. That's why the AquaTru comes with a one-year limited warranty.

Once you've experienced the purity of AquaTru water, visit us at [AquaTru.com](http://AquaTru.com) to find out more ways to improve the quality of your water and your life with our premium products and upgrades.

Please be sure to read the following instructions carefully before use to ensure optimal performance and safety.

[AquaTru.com](http://AquaTru.com)

AquaTru®, LLC  
P.O. Box 9169  
Van Nuys, CA 91409-8291  
800.220.6570

# Table of Contents

---

|                                       |           |
|---------------------------------------|-----------|
| <b>Safety Instructions</b>            | <b>2</b>  |
| <b>Features</b>                       | <b>4</b>  |
| <b>Specifications</b>                 | <b>5</b>  |
| <b>Main Parts</b>                     | <b>6</b>  |
| <b>Water Filtration Process</b>       | <b>8</b>  |
| <b>Installation</b>                   | <b>9</b>  |
| <b>How To Use</b>                     | <b>11</b> |
| <b>Cleaning</b>                       | <b>12</b> |
| <b>Maintenance/Filter Replacement</b> | <b>13</b> |
| <b>FAQ &amp; Troubleshooting</b>      | <b>15</b> |
| <b>One-Year Limited Warranty</b>      | <b>18</b> |
| <b>Arbitration Agreement</b>          | <b>19</b> |

## Read and Save These Instructions

**WARNING: IF NOT OBSERVED, SERIOUS PHYSICAL INJURY OR PROPERTY DAMAGE MAY OCCUR AS A RESULT OF NOT FOLLOWING THE ENCLOSED GUIDELINES.**

**WARNING: Use only on municipally-treated water or any other water supply known to be microbiologically safe.**

- Do not repair, disassemble, or modify.
- This appliance is not intended for use by persons (including children) with reduced physical, sensory or mental capabilities, or lack of experience and knowledge, unless they have been given supervision or instruction concerning use of the appliance by a person responsible for their safety.
- Children should be supervised to ensure that they do not play with the appliance.

## READ ALL INSTRUCTIONS BEFORE OPERATING THE AQUATRU.

- Use or place the unit on a level area and do not apply force to the unit.
- Use or place in a cool, shady place away from sunlight. Do not keep AquaTru in bright sunlight, since the light and heat helps algae grow.
- Periodic filter replacement is a prerequisite for obtaining clean water.
- Do not use AquaTru filtered water for the water exchange of an aquarium or a fishbowl.
- Hand wash only. **Not dishwasher safe!**
- Household use only.
- Do not operate below 40° F.
- When placing AquaTru on a kitchen countertop, always avoid placing near hot surfaces like stoves and ovens.

## NOTICE: TO REDUCE THE RISK ASSOCIATED WITH PROPERTY DAMAGE DUE TO WATER LEAKAGE:

- Read and follow these instructions before installation and use of the AquaTru.
- To protect from freezing, remove filter cartridges when temperatures are expected to drop below 40° F.
- Do not use in areas when temperatures may exceed 100° F.
- Do not place the AquaTru in direct sunlight.

## FCC Statement

This equipment has been tested and found to comply with the limits for a Class B digital device, pursuant to part 15 of the FCC Rules. These limits are designed to provide reasonable protection against harmful interference in a residential installation. This equipment generates, uses and can radiate radio frequency energy and, if not installed and used in accordance with the instructions, may cause harmful interference to radio communications. However, there is no guarantee that interference will not occur in a particular installation. If this equipment does cause harmful interference to radio or television reception, which can be determined by turning the equipment off and on, the user is encouraged to try to correct the interference by one or more of the following measures:

- Reorient or relocate the receiving antenna.
- Increase the separation between the equipment and receiver.
- Connect the equipment into an outlet on a circuit different from that to which the receiver is connected.
- Consult the dealer or an experienced radio/TV technician for help.

**Changes or modifications not expressly approved by the party responsible for compliance could void the user's authority to operate the equipment.**

This device complies with part 15 of the FCC Rules. Operation is subject to the following two conditions:

1. This device may not cause harmful interference.
2. This device must accept any interference received, including interference that may cause undesired operation.

## IC Warning

This device contains licence-exempt transmitter(s)/receiver(s) that comply with Innovation, Science and Economic Development Canada's licence-exempt RSS(s). Operation is subject to the following two conditions:

1. This device may not cause interference.
2. This device must accept any interference, including interference that may cause undesired operation of the device.

Cet appareil contient des émetteurs / récepteurs exemptés de licence conformes aux RSS (s) d'Innovation, Sciences et Développement économique Canada. Le fonctionnement est soumis aux deux conditions suivantes :

1. Cet appareil ne doit pas causer d'interférences.
2. Cet appareil doit accepter toutes les interférences, y compris celles susceptibles de provoquer un fonctionnement indésirable de l'appareil.

**The distance between user and products should be no less than 8 inches.  
La distance entre l'utilisateur et le produit ne doit pas être inférieure à 20 cm.**

## Advanced 4-Stage Purification System

The AquaTru water purification system provides powerful quadruple purification performance utilizing Ultra Reverse Osmosis technology.

## Cost Savings Efficiency

Avoiding bottled water cost by creating your own clean water, and long lasting filters all add up to significant savings over the life of the product.

## One-Touch Water Dispensing

Simple intuitive one-touch controls for dispensing water.

## Space Saving and Compact Design

Efficient and elegant countertop design takes up minimal space in the kitchen.

## Quick Filter Replacement

Easy access to the filter bay to replace filters. No tools required!

## Easy Installation

Ready to use in less than 10 minutes.

## Connected Smart App

Track water usage, filter life, TDS levels and plastic bottles saved. Download and install the Apple® or Android® AquaTru app. For further information, please visit [aquatruwater.com/wifi-onboard](http://aquatruwater.com/wifi-onboard).



# Specifications

| OPERATING PARAMETERS                     | IMPERIAL                       | METRIC UNITS            |
|--|--------------------------------|-------------------------|
| <b>Input Power</b>                       | 100-240 Volt ~ 50-60 Hz        | 100-240 Volt ~ 50-60 Hz |
| <b>Temperature</b>                       | 40-100° F                      | 4-38° C                 |
| <b>Inlet Water Quality Limits</b>        |                                |                         |
| <b>Total Dissolved Solids (TDS)</b>      |                                | 1500 mg/L               |
| <b>Maximum Hardness ††:</b>              | 10 gpg                         | 171 mg/L                |
| <b>Sulphide, Iron &amp; Manganese †:</b> |                                | <0.1 mg/L               |
| <b>Chlorine</b>                          |                                | <2 ppm                  |
| <b>pH</b>                                |                                | 3-11                    |
| <b>Turbidity</b>                         |                                | 5 NTU Max.              |
| <b>Recovery - 80%</b>                    | Daily Production Rate - 54 GPD | Efficiency - 75%        |

† If the hardness of your water is above 10 gpg (171 mg/L), lime scale will build up rapidly on the membrane inside of the RO membrane cartridge. Scale build up will plug up the RO membrane cartridge and make the system ineffective. We do not recommend the AquaTru to be used with water in excess of 10 gpg (171 mg/L) hardness, unless the water is softened prior to pouring into the Ultra Reverse Osmosis system.

# Main Parts

1. Side Panel
2. Pre/Carbon Filter (Part# **AT2001**)
3. Reverse Osmosis Filter (Part# **AT2002**)
4. VOC Carbon Filter (Part# **AT2003**)
5. Filtered Water Tank (Part# **AT3004**)
6. Unfiltered Tap Water Tank (Part# **AT3005**)
7. Dispensing Button
8. Display
9. Power Adapter (universal voltage)

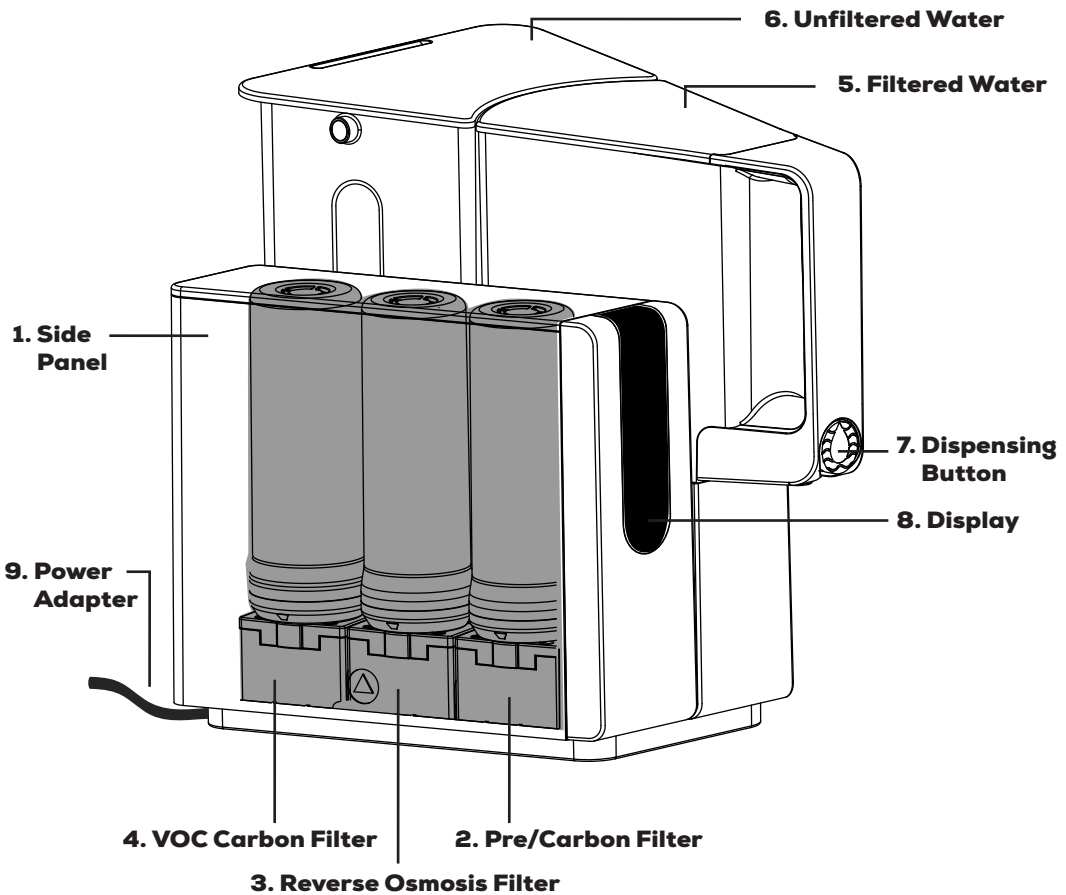



# Main Parts



# Water Filtration Process

## 4-Stage Purification Process:

### Stages 1 & 2: Dual Stage Pre-Filter

The Pre-Filter removes sand, silt, sediment, rust and particles from water. Activated carbon eliminates chlorine taste and odors and then conditions the water before it is treated by the reverse osmosis membrane.

### Stage 3: Reverse Osmosis (RO) Filter

The RO membrane reduces impurities from the water down to 1/10,000 of a micron.

### Stage 4: VOC Carbon Filter

This Carbon Filter is made of high quality activated carbon. It is designed to remove volatile organic compounds, enhance the taste and prepare the water for consumption.

## Unfiltered Water Tank

## Filtered Water Tank

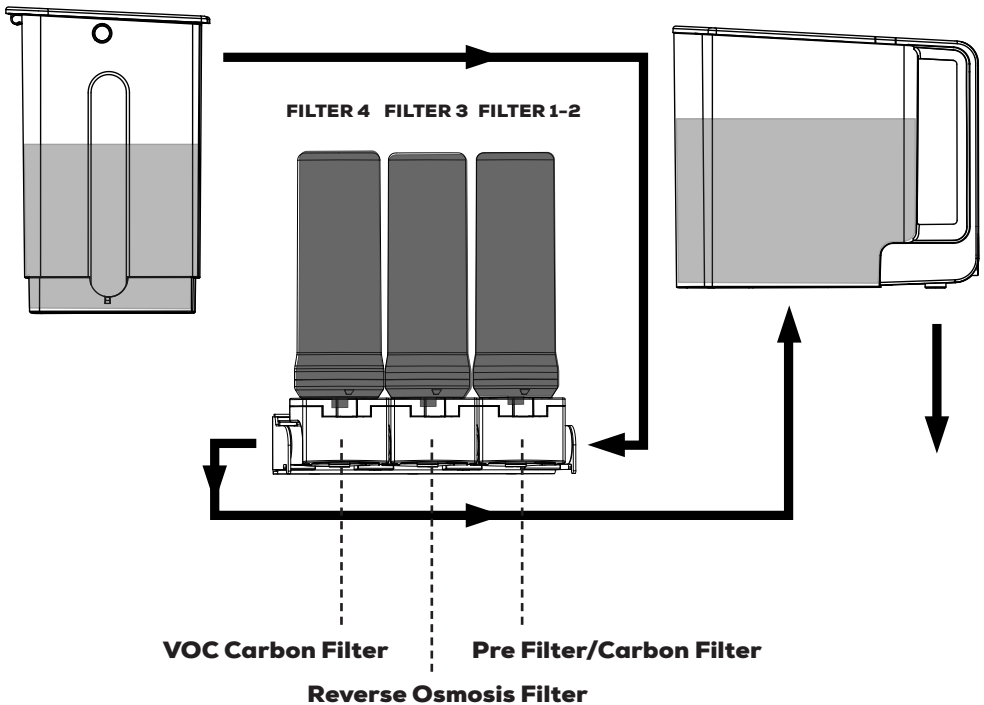

# Installation

**WARNING:** Use and store the AquaTru in a cool, shady place, away from sunlight. Do not keep your AquaTru in sunlight, since the bright light and heat helps algae grow.

**CAUTION:** Before installing the filters and cleaning the water tank, make sure that you have thoroughly cleaned your hands and your working surfaces are sanitized.

1. Remove all parts from the box.
2. Wash with soap and rinse both water tanks before using unit.
3. Open side panel by lifting up from bottom.

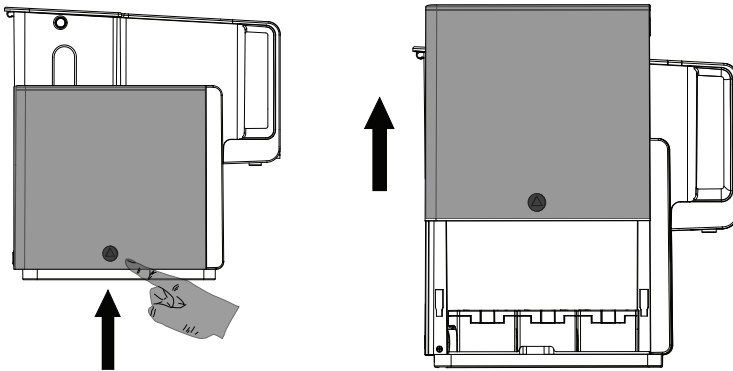

4. Remove filters from vacuum-sealed bag.
5. Insert filters into each filter base by turning the filter in a clockwise direction.
6. When installing filters be sure to insert them into the correct base by matching the label numbers and colors. Line up the RED arrow on the filter with the RED arrow on the base. **Please note:** the filter base pivots outward to make removing and reinstalling filters more accessible.
7. Pivot the filter back to its vertical upright position.
8. Close the side panel.

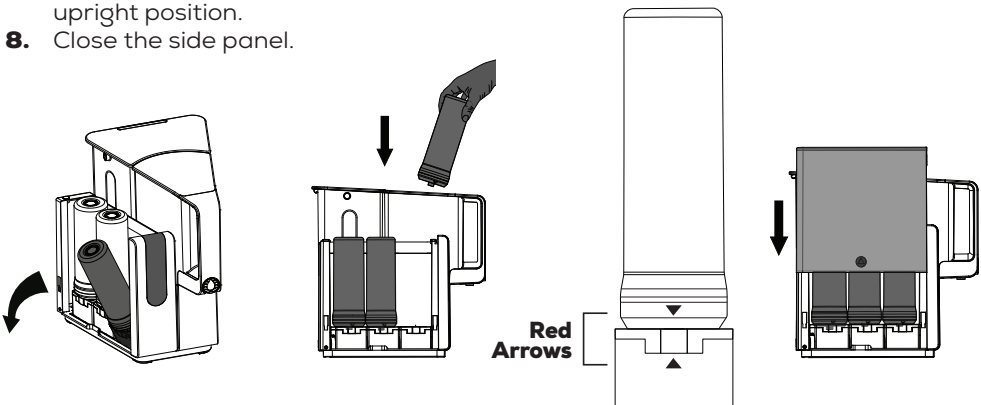

**HELPFUL TIP:**

If you find it difficult to screw in the filter, wet the O-ring on the filter housing by holding it under the cold water faucet for a quick second.

9. Fill tap water tank with cold tap water and then reinstall. Be sure that both tanks are properly seated. This can be done by pressing down on the tanks once in place.
10. Plug in unit.
11. Power on the AquaTru using the switch located on the back.

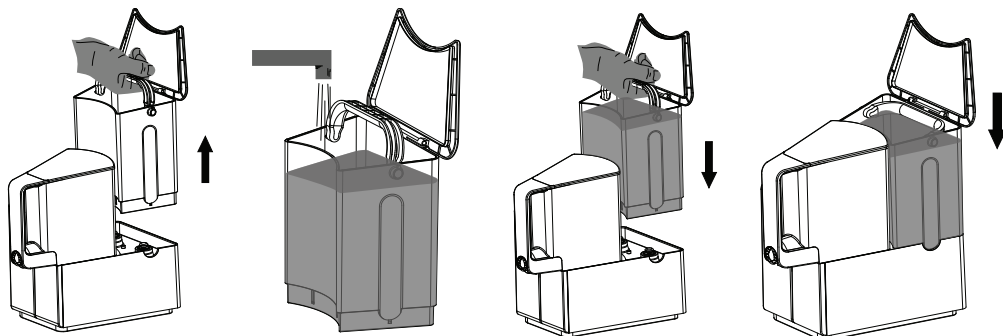

## First Time Start-Up Procedure

**Run 4 full, unfiltered cold (tap) water tanks through the AquaTru before drinking.**

12. Once the tanks have been installed on the unit and the unit is turned on, it will begin to filter water automatically.

**Note:** It will take longer than normal for the first tank to go through a cycle. A white cloud will be visible in the tap water tank. **This is perfectly normal, the white cloud represents tiny air bubbles released by the RO membrane.**

**NOTICE: Keep a close eye for any water leaks. In case of a leak, check the "Troubleshooting" guide on pages 12-13.**

13. AquaTru will stop filtering water when the clean water tank is full or when it is time to refill the tap water tank.

**Note:** When it is time to refill the unfiltered (tap) water tank it will be a quarter full.

## WASTER WATER SCALING RISK

**AquaTru works by recirculating water many times, leaving concentrated contaminants in the tap water tank. Therefore, you must discard the waster water (remaining water in tap tank) before refilling. Failure to discard this highly concentrated waster water will cause contaminants to form scale on internal parts and cause product failure.**

**The water in the tap water tank must be discarded every time you refill the tap water tank. Failure to do so will damage the unit and void the warranty.**

14. Empty and rinse both water tanks.
15. Repeat steps 8-12, 3 more times.
16. When 4 cycles have been completed, your AquaTru is ready to be used.

# How To Use

**CAUTION:** Before installing the filters and cleaning the water tank make sure that you have thoroughly cleaned your hands and your working surfaces are sanitized.

**WARNING:** Use only on municipally treated water or any other water supply known to be microbiologically safe.

1. Fill the unfiltered water tank with cold tap water and install on the AquaTru base.
2. Let AquaTru cycle until the front display turns off and your front filtered water tank is full.
3. When it is time to refill the unfiltered water tank, the display will illuminate the top circle. (Figure 1) Remove tank and **discard the remaining water**. Refill the unfiltered tap tank with cold tap water until it reaches just below the tank handle. Reinstall tank.
4. Press the blue button to dispense water.

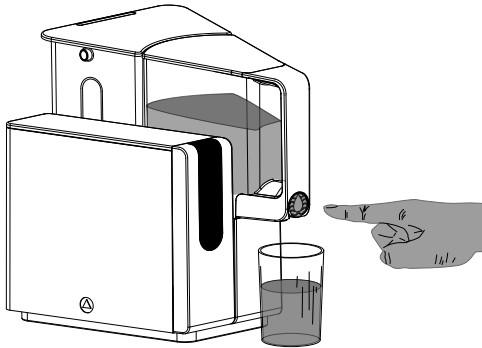
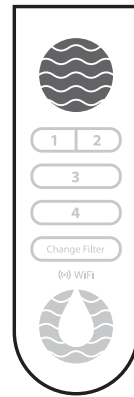
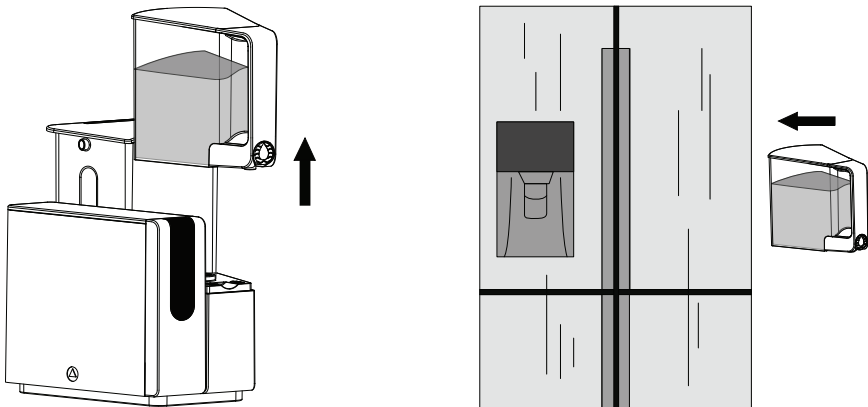

Figure 1



5. You can also remove the water tank and place it in the refrigerator to make cold water.



Visit our website at [aquatru.com](http://aquatru.com) to order extra water tanks to continually purify and refrigerate water.

## Cleaning

**Tanks** – Clean both water tanks every week with soap and water, inside and out. When cleaning, be sure to release soapy water from spout and tank valves on the bottom of each tank. This can be done by pressing the dispense button and spring-loaded white pin at the bottom of the tank.

**Please note:** Sometimes it might be necessary to let the tanks dry for a couple of hours before use.

---

## Mineral Scale Deposit in Tap Water Tank

If you live in an area with hard water, you might see white scale deposits in the tap water tank. It is important that you always make sure that you keep your tap water tank free of scale deposits by washing the tap water thoroughly with dish soap and water as instructed and once per week. If you are not able to remove the deposit with water and dish soap, we recommend you use a solution of warm water and one AquaTru Descaling Powder packet. Let the tank soak for 1 hour before you scrub the inside of the tank, and the wash tank valve with a soft non-abrasive sponge before washing with soap and water. Make sure that you remove all of the scale deposits in both the tank and the valves that are inside the bottom of the tank.

---

## Algae in the Water Tanks

In order to avoid algae from growing in the tap water and clean water tanks, you need to wash them weekly and keep AquaTru away from heat sources and direct sunlight. In case of algae growth, we suggest that you soak the tanks in a bleach solution for 1 hour before washing with soap and water.

---

**Unit/Base** – Clean the outside of the unit using a non-abrasive sponge or towel with soap and water. To avoid water spots; use a clean drying towel to thoroughly dry all surfaces of the AquaTru.

**Please note:** During normal use, small amounts of water may occasionally leak from valves. Use a dry towel to soak up any spillage before reinstalling tanks.

## Filter

AquaTru will track the usage of your filters and let you know when it's time for them to be changed. When the time comes, the front display will notify you by illuminating the Change Filter light and the filter that needs changing.

During normal use, the lights will move from filter to filter to indicate that the water is cycling through the purifying process.

When the filter needs to be changed, the filter light will remain lit on the filter that needs to be changed. After Replacement, press the filter reset button located on the back of the unit for **3 seconds**, or until the illuminated lights disappear and resume cycling through the filter numbers as normal.

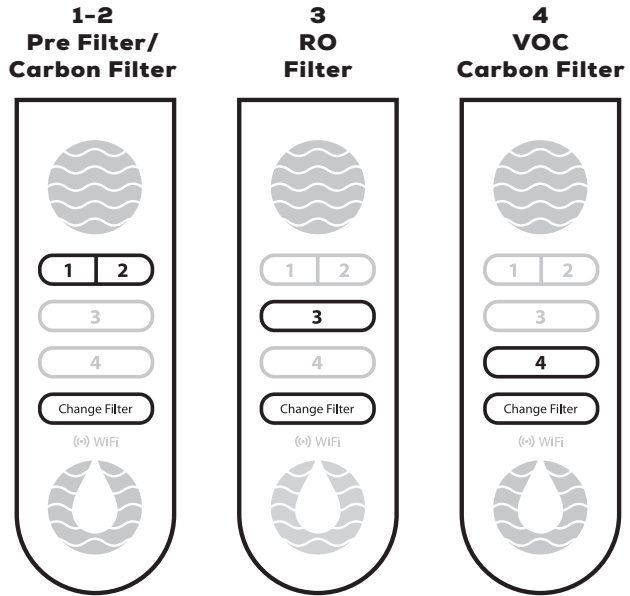

**Please visit our website to purchase replacement filters / [aquatru.com](http://aquatru.com)**

**NOTE: Depending on the water quality where you live and your usage of AquaTru, more frequent replacement of the RO filter might be needed. If the filtering time of 1 tank takes longer than 30 minutes (normally it should take about 10-15 minutes), we recommend completing descaling maintenance using AquaTru's Descaling Kit and replacing your RO filter regardless of if the filter change light is on or not.**

The reason for the longer filtering time is due to scale in the water, also called hard water. Mineral scale will build up on the RO membrane and block the water flow. This in turn will add extra stress to the pump and filter, causing them to fail.

## Filter Replacement

### WARNING:

**After removing the cover, wait 60 seconds in order to depressurize the filters before removing the filters. After replacing a filter, discard the first 2 full water tanks that AquaTru produces.**

1. Pivot the filter outward to make it easier to remove (Figure 1).
2. Remove old filter by turning it counter clockwise (Figure 1).
3. Install new filter by turning it clockwise. Be sure to tighten securely. **HELPFUL TIP:** If you find it difficult to screw on the filter, wet the O-ring on the filter housing by holding it under the cold water faucet for a few seconds.
4. Pivot the filter back to its vertical upright position.
5. Close side panel.
6. Press the **Filter Reset Button** located on the back of the AquaTru unit (Figure 2). Press and hold it for at least **5 seconds**, or until the filter light turns off.
7. After installing a new filter, always discard the first two full water tanks the AquaTru produces.

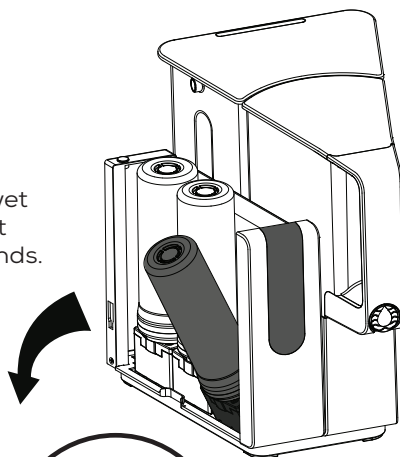

Figure 1

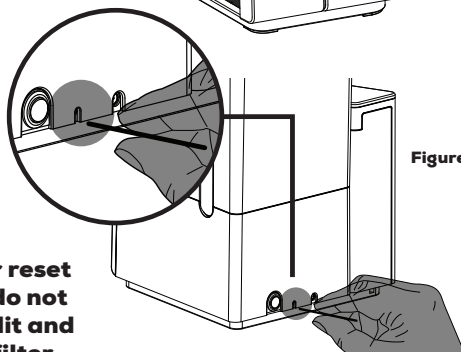

Figure 2

**IMPORTANT: Once you have installed the new clean filters, you must press the filter reset button located on the back of the unit. If you do not do this step, the filter light indicator will stay lit and the AquaTru will not track the life of the new filter.**

|                   |  |  |
|-------------------|--|--|
| <b>Filter 1-2</b> |  | Pre/Carbon Filter (Part# <b>AT2001</b> )   |
| <b>Filter 3</b>   |  | Reverse Osmosis Filter (Part# <b>AT2002</b> )  |
| <b>Filter 4</b>   |  | VOC Carbon Filter (Part# <b>AT2003</b> ) or<br>VOC Carbon with pH + Mineral Boost (Part# <b>AT2004</b> ) |

## Long Term Storage / Vacation

If leaving on vacation, start by switching the unit off. Next, wash both tanks with soap and water. Allow the tanks to dry thoroughly before reinstalling them. When you have returned from vacation, purge the system of stagnant water by running 4 full tap water tanks through the system. Once the fourth tank has been filtered, the unit is ready to use. This process can be avoided by having a house sitter run one tank of tap water through the AquaTru at least once a week.



## Early Filter Reset

1. To enter Reset mode, press and hold the **Filter Reset Button** for 10 seconds or until the 3 filter indicators light up.
2. A single press of the **Filter Reset Button** will cause the Filter 1-2 indicator light to blink. Pressing the button again will make the Filter 3 light blink; pressing it an additional time will cycle to Filter 4. Pressing Reset once again will go back to Filter 1-2.
3. Once the filter you want to reset is blinking, press and hold the **Filter Reset Button** for 5 seconds to reset the filter life. The light will blink rapidly for a few seconds indicating that the filter has been successfully reset.
4. If you decide you do not want to reset any of the filters early, leave the unit untouched for 15 seconds, and it will automatically exit out of filter reset mode.

**CAUTION: Before doing any maintenance or troubleshooting, make sure that you have thoroughly cleaned your hands and your working surfaces are sanitized.**

**WARNING: To refill the tap water tank, ALWAYS remove the tank and discard the remaining water BEFORE refilling.**

| PROBLEM   | REASON  | SOLUTION  |
|---|---|---|
| <b>Unit will not power on</b>                               | Unit is not plugged in.   | Plug power adapter into unit. Then plug power cord into GFCI equipped outlet.   |
|   | Power switch is not on.   | Turn power switch on, located on back of the unit.  |
|   | Filter cover is not fully installed.  | Check to make sure that the filter cover is fully installed.<br><br>Check to make sure the magnet on the inside of the cover is present. It will be on the lower left corner of the filter cover.   |
|   | Tanks are not fully seated.   | Press down on both tanks to make sure they are fully seated.  |
| <b>Clean water tank is empty but AquaTru will not start</b> | Tap water tank is empty.  | Fill up the tap water tank.   |
|   | Tanks are not properly seated.  | Reinstall both tanks.   |
|   | You did not remove tap water tank when you refilled it.<br><br>The water level sensor in the top of the clean water tank might be wet or have soap on them. | The tap water tank always has to be removed from the base and remaining water has to be discarded. Failure to do so will void warranty and the unit will stop filtering water.<br><br>Remove the clean water tank and rinse the inside. Make sure that you rinse the water sensor in the top of the tank, close to the handle. Shake water away from the water level sensor before reinstalling. If this did not help, wait a couple of hours to allow the tank to dry, before trying to restart AquaTru. |
| <b>The top circle is illuminated</b>                        | The tap water tank is empty.  | Refill tap water tank.  |

| PROBLEM  | REASON  | SOLUTION  |
|--|---|---|
| <b>Water tanks smell</b>                         | The water tank is dirty.  | Wash water tank with soap and water once a week. <b>Note:</b> Use and store AquaTru in cool, shady place away from sunlight. Do not keep your AquaTru in sunlight, since sunlight and heat can facilitate algae growth.   |
| <b>Water tanks are leaking</b>                   | Tanks are not properly seated.<br><br>The valve may not be closing properly.<br><br>You might have accumulated calcium scale on the valves.                               | Reinstall tanks.<br><br>To test valve, press the small white pin with spring located at the bottom of either tank. Do this above a sink as water will release from the tank.<br><br>AquaTru Descaling Powder is recommended. Fill the scaled tank with a solution of warm water and descaling powder. Let stand for at least 30 minutes. Drain by pushing on the valve under the tanks. Thoroughly wash and rinse tanks before reinstalling. You can order AquaTru Descaling Powder at AquaTru.com. Alternatively, you may use equal parts warm water and vinegar solution.                             |
| <b>AquaTru is filtering slower than usual</b>    | The filter might have come to the end of its life. As the RO Filter gets older, the filtering time may increase.<br><br>The RO Filter may have become completely clogged. | Depending on the water quality where you live and your pattern of usage of the AquaTru, more frequent replacement of the RO Filter might be needed. If the filtering time of 1 tank takes longer than 30 minutes (normally it should take about 10-15 minutes), we recommend completing descaling maintenance using AquaTru's Descaling Kit and replacing your RO Filter regardless of if the filter change light is on or not.<br><br>Replace RO Filter. Part# AT2002. Very hard water can slow down the filtering time. Note that longer filtering times do not impact the efficiency of the filters. |
| <b>My clean water has higher TDS than before</b> | New VOC Carbon Filter has been installed.<br><br>RO Filter may need to be changed.  | Run four tap water tanks to rinse out particles from new carbon filter.<br><br>Generally, RO system lowers TDS readings by 90% as compared to tap water readings. If you see less than 80% reduction, you need to replace the RO Filter.  |
| <b>AquaTru makes a strange noise</b>             | Normal pump operation.<br><br>New filter installation.  | The water pump will make noise during water filtration.<br><br>Some filters make extra noise as they become saturated. This is normal and should reduce in time.  |
| <b>Bad tasting water</b>                         | New filters have not been flushed completely.<br><br>Filter may need to be replaced.<br><br>The water tanks are dirty.  | Run four tap water tanks to rinse out particles when it is a new filter.<br><br>Order new filters at AquaTru.com.<br><br>Wash water tanks with soap and water once a week.  |

## FAQ & Troubleshooting

| PROBLEM  | REASON   | SOLUTION  |
|--|--|---|
| <b>Water dispenser is leaking</b>  | A small amount of water may leak from the front spout.   | Avoid by holding water receptacle in place for an extra moment when dispensing water. This will allow you to catch the remaining water.   |
| <b>Leaking water from unit</b>   | Filters installed incorrectly.<br><br>Defective filter.  | Reinstall each filter. Remove the filter O-ring and reinstall the O-ring ensuring that each has been properly seated. Wet the O-ring with clean water before installing filter.<br><br>Compare each filter to make sure that all outside O-rings are identical in size. Filters should fit tightly when installed. If loose, the filter is defective.   |
| <b>Filter light is on and won't turn off</b>   | Filter needs to be replaced.   | Replace the filter that is illuminated, then press the filter reset button for at least 3 seconds on the back of the unit.  |
| <b>White cloudiness in the tap water tank</b>  | Micro air bubbles from RO Filter.  | This is normal and may be experienced during every use.   |
| <b>My tap water tank has white scaling</b>   | The tanks has accumulated minerals from the tap water.   | AquaTru Descaling Powder is recommended to descale your tank. Fill the scaled tank with a solution of warm water and descaling powder. Let sit for 30 minutes to 1 hour before cleaning with a non-abrasive sponge. Thoroughly wash and rinse tanks before reinstalling on your AquaTru. You can order AquaTru Descaling Powder at AquaTru.com. Alternatively, you may use equal parts water and distilled vinegar. |
| <b>When I installed new filters water started leaking from the bottom of the AquaTru</b> | When filters are changed, it is normal for some water to escape the filter base and leak into the bottom of the unit. There are holes located on the bottom of the unit to allow the water to drain. | Wait 60 seconds after removing the cover, before removing the filter. This will minimize the spillage.  |

## One-Year Limited Warranty

Your AquaTru water purifier is warranted to be free from defects in materials and workmanship for one year from the original purchase date. Should the product have a defect in materials or workmanship, we will repair or replace it without charge to you (a shipping and processing fee will apply). **Warranty does not include filters.** To obtain service under warranty, simply call our customer service center toll-free at **800.220.6570**.

This warranty does not cover filters, damage caused by accident, misuse or any use other than as intended and described in this product manual, or damage resulting from failure to maintain and clean this product as also specified in this product manual. This warranty applies only to the original purchaser of the AquaTru water purifier.

**ALL EXPRESS AND IMPLIED WARRANTIES FOR THIS PRODUCT, INCLUDING IMPLIED WARRANTIES OF MERCHANTABILITY AND FITNESS FOR A PARTICULAR PURPOSE, ARE LIMITED IN DURATION TO THE WARRANTY PERIOD, AND NO WARRANTIES, WHETHER EXPRESS OR IMPLIED, WILL APPLY AFTER THIS PERIOD.**

Some states do not allow limitations on the duration of implied warranties, so the above limitation may not apply to you. While this warranty gives you specific legal rights, you may also have other rights which may vary from state to state.

### Contact Info for Warranty Service:

AquaTru®, LLC

P.O. Box 9169 | Van Nuys, CA | 91409-8291  
1.800.220.6570 | AquaTru.com

©2022 AquaTru®, LLC. All Rights Reserved.  
Patents 9,422,173, D731,025.

# Arbitration Agreement

**PLEASE READ THIS AGREEMENT CAREFULLY. YOU ACCEPT THE TERMS OF THIS AGREEMENT BY RETAINING THE PRODUCT(S) SHIPPED IN CONNECTION WITH THIS AGREEMENT (THE "PRODUCTS") FOR MORE THAN THIRTY (30) DAYS AFTER RECEIPT. IF YOU DO NOT AGREE TO THE TERMS OF THIS AGREEMENT, YOU MAY RETURN THE PRODUCT TO COMPANY WITHIN THIRTY (30) DAYS OF RECEIPT FOR A FULL REFUND.**

**THIS ARBITRATION AGREEMENT ("AGREEMENT") AFFECTS YOUR LEGAL RIGHTS AND REMEDIES BY PROVIDING THAT DISPUTES BETWEEN YOU AND THE MANUFACTURER, DISTRIBUTOR AND/OR SELLER OF THIS PRODUCT (COLLECTIVELY, "COMPANY"), MUST BE RESOLVED THROUGH BINDING ARBITRATION AND NOT IN COURT. IT ALSO PROVIDES THAT ANY DISPUTE CANNOT BE RESOLVED IN A CLASS ACTION OR OTHER PROCEEDING WHERE YOU REPRESENT OTHER PERSONS OR OTHER PERSONS REPRESENT YOU, AND THAT NO CLASS OR REPRESENTATIVE ARBITRATIONS ARE PERMITTED. PLEASE CAREFULLY READ ALL TERMS IN THIS AGREEMENT.**

## **1. RESOLUTION OF CLAIMS OR DISPUTES.**

Any claim or dispute between you and Company (or any of Company's subsidiaries or affiliates) arising out of or relating in any way to the Product or this Agreement shall be resolved through final, binding arbitration. This arbitration obligation is reciprocally binding on both you and the Company and applies regardless of whether the claim or dispute involves a tort, fraud, misrepresentation, product liability, negligence, violation of a statute, or any other legal theory. Both you and Company specifically acknowledge and agree that you waive your right to bring a lawsuit based on such claims or disputes and to have such lawsuit resolved by a judge or jury.

## **2. LIMITATION OF LEGAL REMEDIES.**

All arbitrations under this Agreement shall be conducted on an individual (and not a class-wide) basis, and an arbitrator shall have no authority to award class-wide relief. You acknowledge and agree that this Agreement specifically prohibits you and the Company from commencing arbitration proceedings as a representative of others or joining in any arbitration proceedings brought by any other person. The parties agree that no class or representative actions of any type are permitted.

## **3. ARBITRATION PROCEDURES.**

- a.** Before instituting an arbitration, if you have any dispute, we strongly encourage you to contact the Company to try to resolve the matter by calling 800.218.3560, although you are not required to do so.
- b.** The arbitration of any claim or dispute under this Agreement shall be conducted in accordance with the expedited procedures set forth in the JAMS Comprehensive Arbitration Rules and Procedures as those Rules exist on the date you receive the Product, including Rules 16.1 and 16.2 of those Rules. These rules and procedures are available by calling JAMS or by visiting its web site at [www.jamsadr.com](http://www.jamsadr.com). The arbitration of any claim or dispute under this Agreement shall be conducted by an arbitrator who has at least five years of experience conducting arbitrations.
- c.** The arbitration of any claim or dispute under this Agreement shall be conducted in the State of California or the location in which you received this Agreement. For claims of \$10,000 or less, you may choose whether the arbitration proceeds in person, by telephone, or based only on submissions.
- d.** The Company shall pay costs for the arbitration of claims, including any JAMS Case Management Fee and all professional fees for the arbitrator's services. The Company shall pay the fees and costs of its own counsel, experts and witnesses and shall not be able to recoup them from you even if you do not prevail in the arbitration. Unless otherwise provided by law, you acknowledge and agree that you shall pay the fees and costs of your own counsel, experts and witnesses.

## **4. CHOICE OF LAW.**

The arbitration provisions of this Agreement and any arbitration conducted pursuant to the terms of this Agreement shall be governed by the Federal Arbitration Act (9 U.S.C. Secs. 1-16). In this respect, the parties acknowledge that this Agreement involves a transaction conducted in interstate commerce. Otherwise, this Agreement and the rights of the parties hereunder shall be governed by and construed in accordance with the laws of the State of California, exclusive of conflict or choice of law rules.

## **5. SEVERABILITY.**

If any provision of this Agreement is declared or found to be unlawful, unenforceable or void, such provision will be ineffective only to the extent that it is found unlawful, unenforceable or void, and the remainder of the provision and all other provisions shall remain fully enforceable.

# Acuerdo de Arbitraje

**LEA ATENTAMENTE ESTE ACUERDO. USTED ACEPTA LOS TÉRMINOS DE ESTE ACUERDO AL CONSERVAR EL PRODUCTO (LOS PRODUCTOS) ENVIADOS BAJO A ESTE ACUERDO (LOS "PRODUCTOS") POR MÁS DE TREINTA (30) DÍAS DESPUÉS DE SU RECEPCIÓN. SI NO ESTÁ DE ACUERDO CON LOS TÉRMINOS DE ESTE ACUERDO, PUEDE DEVOLVER EL PRODUCTO A LA EMPRESA EN UN PLAZO DE TREINTA (30) DÍAS A PARTIR DE HABERLO RECIBIDO PARA OBTENER UN REEMBOLSO COMPLETO.**

**TESTE ACUERDO DE ARBITRAJE ("ACUERDO") AFECTA A SUS DERECHOS Y RECURSOS LEGALES AL ESTABLECER QUE LAS DISPUTAS ENTRE USTED Y EL FABRICANTE, DISTRIBUIDOR Y/O VENDEDOR DE ESTE PRODUCTO (COLECTIVAMENTE, "COMPAÑÍA"), DEBEN RESOLVERSE MEDIANTE ARBITRAJE VINCULANTE Y NO EN LOS TRIBUNALES. TAMBIÉN ESTABLECE QUE CUALQUIER DISPUTA NO PUEDE SER RESUELTA EN UNA ACCIÓN COLECTIVA U OTRO PROCEDIMIENTO EN EL QUE USTED REPRESENTE A OTRAS PERSONAS O QUE OTRAS PERSONAS LE REPRESENTEN A USTED, Y QUE NO SE PERMITEN ARBITRAJES COLECTIVOS O REPRESENTATIVOS. POR FAVOR LEA DETENIDAMENTE TODOS LOS TÉRMINOS DE ESTE ACUERDO.**

## **1. RESOLUCIÓN DE RECLAMACIONES O DISPUTAS.**

Cualquier reclamación o disputa entre usted y la Compañía (o cualquiera de las subsidiarias o filiales de la Compañía) que surja o esté relacionada de alguna manera con el Producto o este Acuerdo se resolverá mediante un arbitraje final y vinculante. Esta obligación de arbitraje es recíprocamente vinculante tanto para usted como para la Compañía y se aplica independientemente de si la reclamación o disputa implica un agravio, fraude, tergiversación, responsabilidad por el producto, negligencia, violación de una ley o cualquier otra teoría legal. Tanto usted como la Compañía reconocen y aceptan específicamente que renuncian a su derecho a presentar una demanda judicial basada en dichas reclamaciones o disputas y a que dicha demanda sea resuelta por un juez o un jurado.

## **2. LIMITACIÓN DE LOS RECURSOS LEGALES.**

Todos los arbitrajes en virtud del presente Acuerdo se llevarán a cabo de forma individual (y no colectiva), y un árbitro no tendrá autoridad para conceder una reparación colectiva. Usted reconoce y acepta que este Acuerdo le prohíbe específicamente a usted y a la Compañía iniciar procedimientos de arbitraje como representante de otros o unirse a cualquier procedimiento de arbitraje presentado por cualquier otra persona. Las partes acuerdan que no se permiten acciones colectivas o representativas de ningún tipo.

## **3. PROCEDIMIENTOS DE ARBITRAJE.**

- a.** Antes de iniciar un arbitraje, si tiene alguna disputa le recomendamos encarecidamente que se ponga en contacto con la Compañía para intentar resolver el asunto llamando al 800.218.3560, aunque no está obligado a hacerlo.
- b.** El arbitraje de cualquier reclamación o disputa en virtud de este Acuerdo se llevará a cabo de acuerdo con los procedimientos acelerados establecidos en las Normas y Procedimientos de Arbitraje Integrales de JAMS, tal y como existían en la fecha en que usted recibió el Producto, incluidas las Normas 16.1 y 16.2 de dichas Normas. Estas normas y procedimientos están disponibles llamando a JAMS o visitando su sitio web en [www.jamsadr.com](http://www.jamsadr.com). El arbitraje de cualquier reclamación o disputa en virtud de este Acuerdo será llevado a cabo por un árbitro que tenga al menos cinco años de experiencia en la realización de arbitrajes.
- c.** El arbitraje de cualquier reclamación o disputa en virtud de este Acuerdo se llevará a cabo en el Estado de California o en el lugar en el que usted recibió este Acuerdo. En el caso de reclamaciones de \$10,000 o menos, usted podrá elegir si el arbitraje se lleva a cabo en persona, por teléfono o únicamente basado en la presentación de documentación.
- d.** La Compañía pagará los costes del arbitraje de las reclamaciones, incluyendo cualquier tasa de gestión de casos de JAMS y todos los honorarios profesionales por los servicios del árbitro. La Compañía pagará los honorarios y costes de sus propios abogados, peritos y testigos y no podrá recuperarlos de usted aunque no prevalezca en el arbitraje. A menos que la ley disponga lo contrario, usted reconoce y acepta que pagará los honorarios y costes de su propio abogado, peritos y testigos.

#### 4. ELECCIÓN DE LA LEY.

Las disposiciones de arbitraje de este Acuerdo y cualquier arbitraje llevado a cabo de conformidad con los términos de este Acuerdo se regirán por la Ley Federal de Arbitraje (9 U.S.C. Artículos 1-16). A este respecto, las partes reconocen que este Acuerdo implica una transacción realizada en el comercio interestatal. Por lo demás, el presente Acuerdo y los derechos de las partes en virtud del mismo se regirán e interpretarán de acuerdo con las leyes del Estado de California, excluyendo las normas de conflicto o elección de la ley.

#### 5. DISPOSICIONES INDEPENDIENTES.

Si alguna de las disposiciones del presente Acuerdo se declara o se considera ilegal, inaplicable o nula, dicha disposición será ineficaz sólo en la medida en que se considere ilegal, inaplicable o nula, y el resto de las disposiciones y todas las demás cláusulas seguirán siendo aplicables plenamente.

## Transform Water, Transform Lives

We believe an optimized life starts with access to clean water. Every time you buy an AquaTru product, we donate a portion of our proceeds to help communities most in need of access to clean water across the U.S.

We never water down the truth about water injustices across this country, and we invite you to join us in being compassionate, genuinely righteous, **TRU water warriors** for the greater good.



Scan code to Learn more

[aquatru.com/impact](https://aquatru.com/impact)

### Show us how you AquaTru!

Tag and follow us @aquatru

**#TRUwaterwarrior**





AQUATru®  
connect 